

HS6 RING SECTION

Product Code: 50202357

Additional HS6 Riser Ring that will assist in bringing your pit to ground level.

 MATERIAL
High Density Polyethylene (HDPE)

 SIZE
1020mm (L) x 550mm (W) x 170mm (D)

 LOAD RATING
B

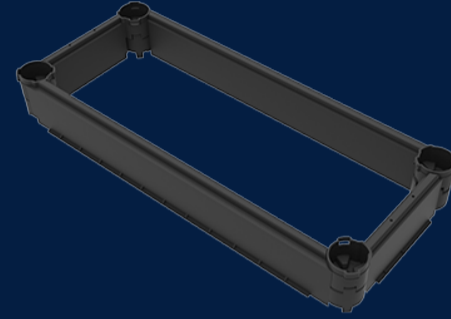

Features & benefits

Stackable Sections

Pit systems are built by stacking sections to required depth.

Strength in the Corners

The fortress is strongest in the corners, where loadings are at their maximum.

Flexible During Installation

Duct entries can be easily created on site using a hole saw and drill. Sections can be cut to build over on existing networks.



Full specifications